

24" Dia. clear opening
with concrete cover

SPECIFICATIONS:

- Concrete: 4000 psi @ 28 days
- Entrained air: 5-9%
- Bar rein: ASTM A 615 GR60
- Fiber rein: Forta Ferro
- I/O baffle Polylok T baffle
- Max earth cover 2'
- Joint seal CS 102
- Plastic Pipe Seals

OPTIONS:

- Cast in EZ-Set risers
- Booted pipe seals
- Booted 4"/6" seal avail.
- Coating inside/outside
- Outlet filter
- Gas baffle

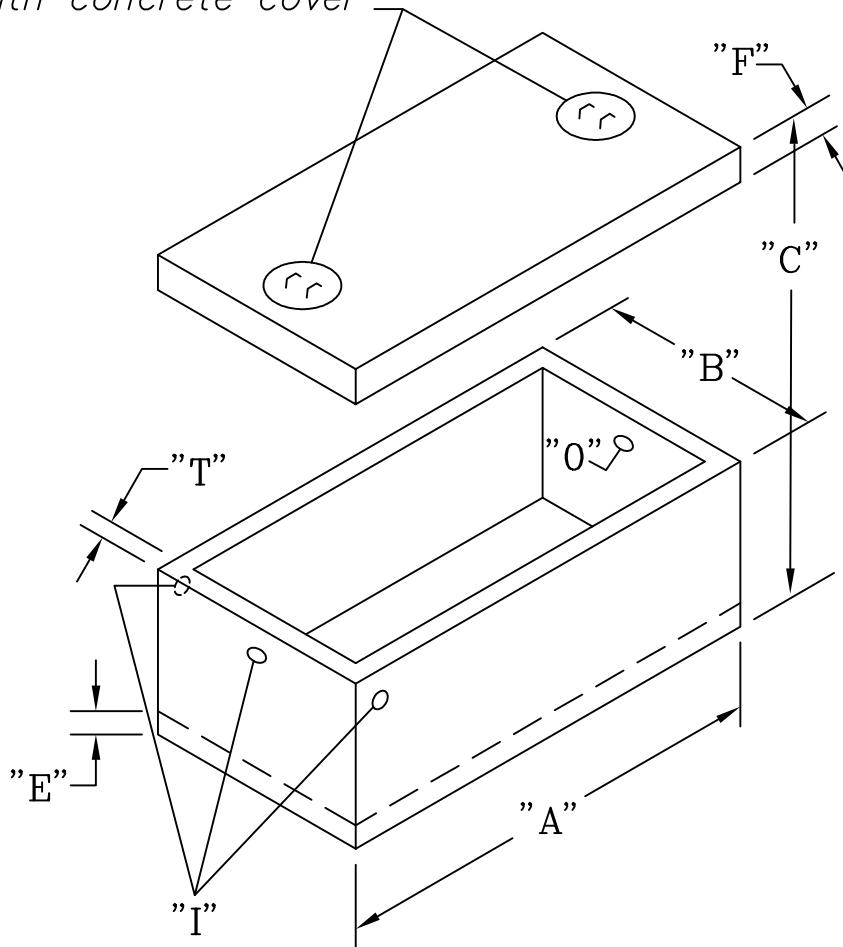

- A = LENGTH
- B = WIDTH
- C = HEIGHT OVERALL
- S = LIQUID LEVEL
- I = INLET
- O = OUTLET
- T = WALL THICKNESS
- F = LID THICKNESS
- E = BASE THICKNESS

DIMENSIONS									
size	A	B	C	I	O	S	T	E	F
1000	115"	61"	65"	51"	48"	43"	4"	5"	8"

**GUARDIAN CONCRETE
PRODUCTS INC.**
2140 Maxon Rd.
Schenectady, NY 12308
Fax (518) 372-6729

**1000 GALLON
SINGLE COMPARTMENT
HEAVY DUTY SEPTIC TANK**

SCALE: NOT TO SCALE	DATE: MARCH 12, 2007
TELEPHONE NO.: (518) 372-0080	JOB: GENERAL CATALOG DRAWING