

24" Dia. clear opening  
with concrete cover

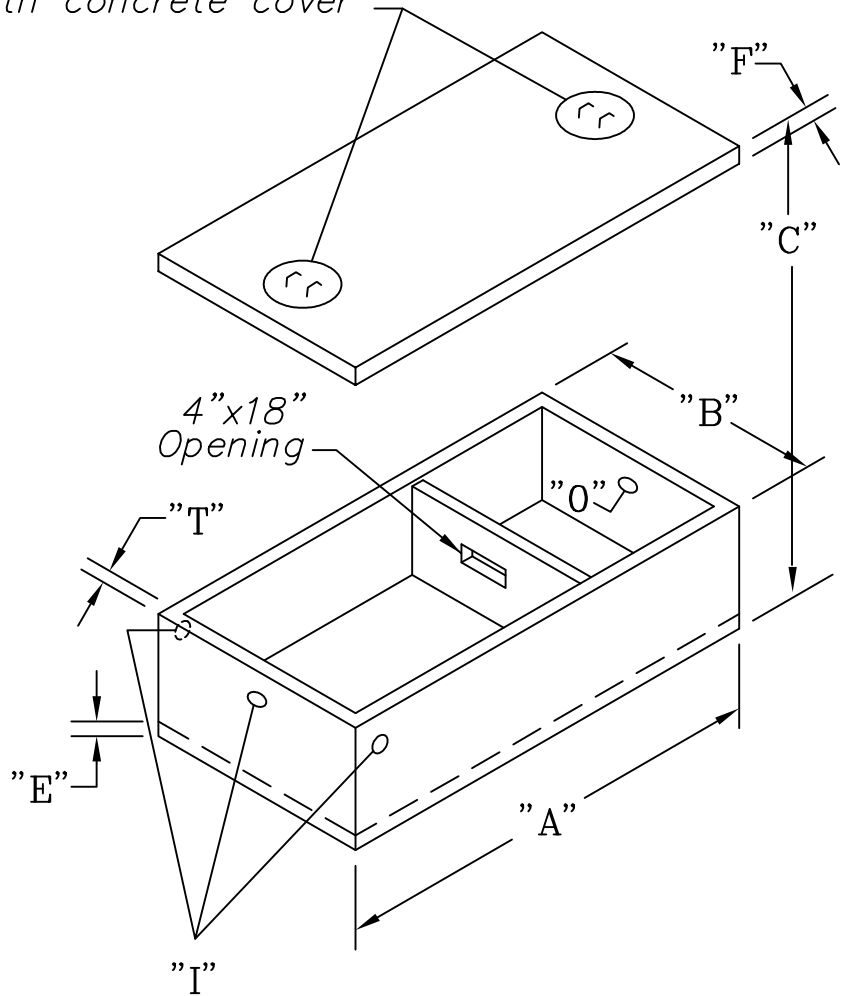

**SPECIFICATIONS:**

- Concrete: 4000 psi @ 28 days
- Entrained air: 5-9%
- Bar rein: ASTM A 615 GR60
- Fiber rein: Forta Ferro
- I/O baffle Polylok T baffle
- Max earth cover 2'
- Joint seal CS 102
- Plastic Pipe Seals

**OPTIONS:**

- Cast in EZ-Set risers
- Booted pipe seals
- Coating inside/outside
- Outlet filter
- Gas baffle

- A = LENGTH
- B = WIDTH
- C = HEIGHT OVERALL
- S = LIQUID LEVEL
- I = INLET
- O = OUTLET
- T = WALL THICKNESS
- F = LID THICKNESS
- E = BASE THICKNESS

DIMENSIONS									
size	A	B	C	I	O	S	T	E	F
1250	151"	79"	49"	38"	35"	31"	3"	4"	4"

**GUARDIAN CONCRETE PRODUCTS INC.**  
2140 Maxon Rd.  
Schenectady, NY 12308  
Fax (518) 372-6729

**1250 38" GALLON  
DUAL COMPARTMENT  
LOW PROFILE SEPTIC TANK**

SCALE: NOT TO SCALE	DATE: MARCH 13, 2007
TELEPHONE NO.: (518) 372-0080	JOB: GENERAL CATALOG DRAWING